

**ADVANCED SUBSIDIARY GCE UNIT
PHYSICS B (ADVANCING PHYSICS)**

2861

Understanding Processes

FRIDAY 12 JANUARY 2007

Afternoon

Time: 1 hour 30 minutes

Additional materials:
Data, Formulae and Relationships Booklet
Electronic calculator
Protractor
Ruler



Candidate
Name

Centre
Number

| | | | | |
|--|--|--|--|--|
| | | | | |
|--|--|--|--|--|

Candidate
Number

| | | | |
|--|--|--|--|
| | | | |
|--|--|--|--|

INSTRUCTIONS TO CANDIDATES

- Write your name, Centre Number and Candidate Number in the boxes above.
- Answer **all** the questions.
- Use blue or black ink. Pencil may be used for graphs and diagrams only.
- Read each question carefully and make sure you know what you have to do before starting your answer.
- Do **not** write in the bar code.
- Do **not** write outside the box bordering each page.
- WRITE YOUR ANSWER TO EACH QUESTION IN THE SPACE PROVIDED. ANSWERS WRITTEN ELSEWHERE WILL NOT BE MARKED.
- Show clearly the working in all calculations, and round answers to only a justifiable number of significant figures.

INFORMATION FOR CANDIDATES

- The number of marks for each question is given in brackets [] at the end of each question or part question.
- The total number of marks for this paper is 90.
- You are advised to spend about 20 minutes on Section A, 40 minutes on Section B and 30 minutes on Section C.
- There are four marks for the quality of written communication in Section C.
- The values of standard physical constants are given in the Data, Formulae and Relationships Booklet. Any additional data required are given in the appropriate question.

| For Examiner's Use | | |
|--------------------|-----------|------|
| Section | Max | Mark |
| A | 20 | |
| B | 40 | |
| C | 30 | |
| Total | 90 | |

This document consists of **20** printed pages.



Answer **all** the questions.

Section A

1

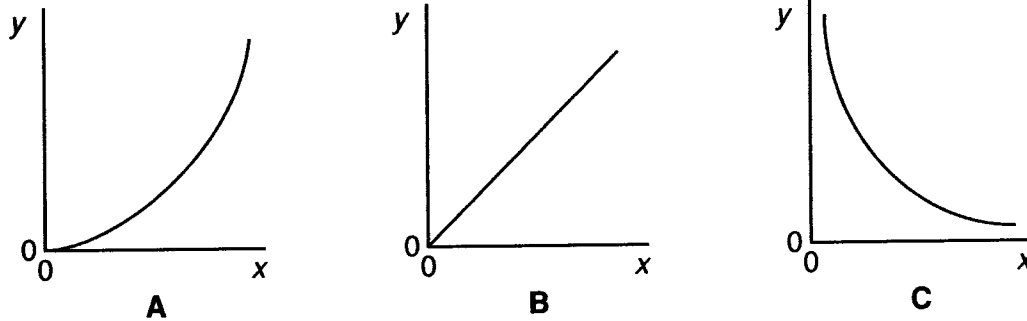

Fig. 1.1

Which graph, **A**, **B** or **C** in Fig. 1.1, is obtained when the y and x axes represent the two quantities given below?

(a) y -axis: the **kinetic energy** of various objects each travelling at the same speed

x -axis: the **mass** of each object

answer [1]

(b) y -axis: the **intensity** of a wave

x -axis: the **amplitude** of the wave

answer [1]

(c) y -axis: the **energy** of a photon of electromagnetic radiation

x -axis: the **wavelength** of the radiation

answer [1]



2 A boy of mass 60 kg drops 1.7 m to the ground from the top of a wall, and lands on his feet.

(a) By considering the energy changes taking place as he falls, calculate his kinetic energy on landing.

$$g = 9.8 \text{ N kg}^{-1}$$

kinetic energy = J [2]

(b) To cushion the force of the impact he bends his knees as he touches the ground. He brings himself safely to rest in the position shown in Fig. 2.1(b).

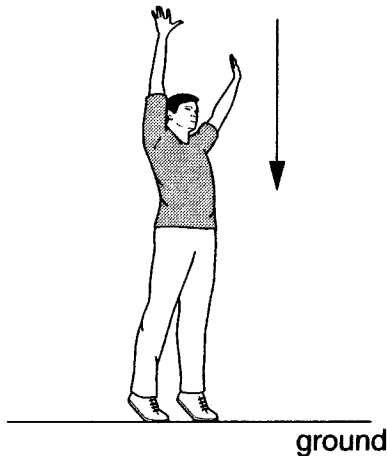

Fig. 2.1(a)

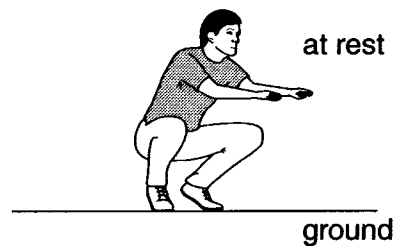

Fig. 2.1(b)

Explain why the forces in his legs are reduced considerably by bending his knees in the way described.



- 3 The table shows the wavelengths and frequencies associated with the photons emitted from three different light emitting diodes (LEDs), labelled **A**, **B** and **C**.

| LED | wavelength / 10^{-7}m | frequency / 10^{14}Hz | colour |
|----------|-----------------------------------|-----------------------------------|--------|
| A | 7.0 | 4.3 | |
| B | 5.8 | 5.2 | |
| C | 5.2 | 5.8 | |

The three colours of light emitted by the LEDs are blue, green and red.

- (a) Complete the table by indicating the colour of light emitted by each LED. [1]
- (b) Calculate the energy of the photon with greatest energy.

the Planck constant = $6.6 \times 10^{-34}\text{Js}$

energy = J [2]



- 4 To illustrate the rotating phasor description of a wave, a teacher uses the picture of an early bicycle shown in Fig. 4.1.

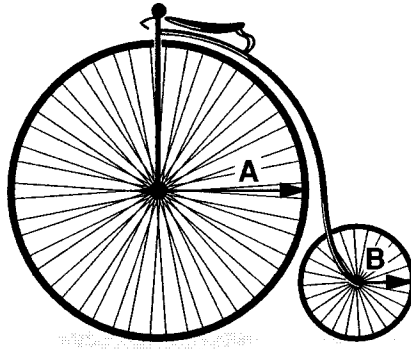

Fig. 4.1

The arrows **A** and **B** drawn on the wheels of the bicycle represent the phasors associated with two waves. As the bicycle moves forward, representing the waves progressing, the phasors rotate anticlockwise.

- (a) State **two** differences between the two waves represented.

[2]

- (b) State **one** similarity between the two waves represented.

[1]



- 5 A beam of electrons is accelerated through a potential difference V in an electron gun. The beam strikes a graphite target in the evacuated tube and the atoms of the target scatter the electrons.

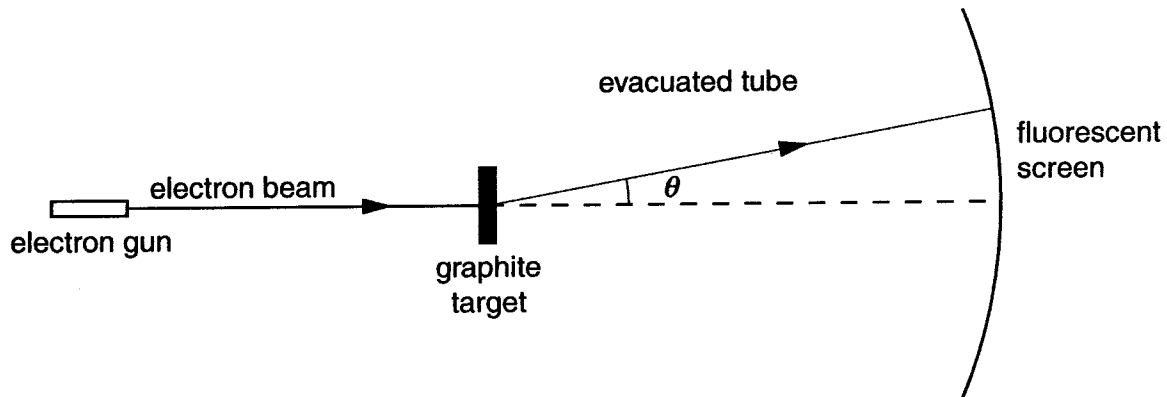

Fig. 5.1

An intense beam of electrons is detected at an angle θ , as shown in Fig. 5.1.

The angle θ through which the beam is diffracted is measured for different values of accelerating potential difference V . The readings are given below, and values of $\sin \theta$ have been calculated in each case.

| V/kV | $\theta/\text{degrees}$ | $\sin \theta$ |
|---------------|-------------------------|---------------|
| 3.0 | 12 | 0.208 |
| 4.0 | 10 | 0.174 |
| 5.0 | 9 | 0.156 |

It is suggested that the relationship between the diffraction angle θ and the accelerating potential difference V is given by:

$$\sin \theta = \frac{k}{\sqrt{V}} \text{ where } k \text{ is a constant for the apparatus.}$$

Propose and carry out a test to check if the relationship is true for **these** data.

test proposed

working

conclusion: [3]



- 6 A motorcycle stunt rider, moving at constant speed, takes off horizontally from a launch point 2.0 m above the ground, as shown in Fig. 6.1.

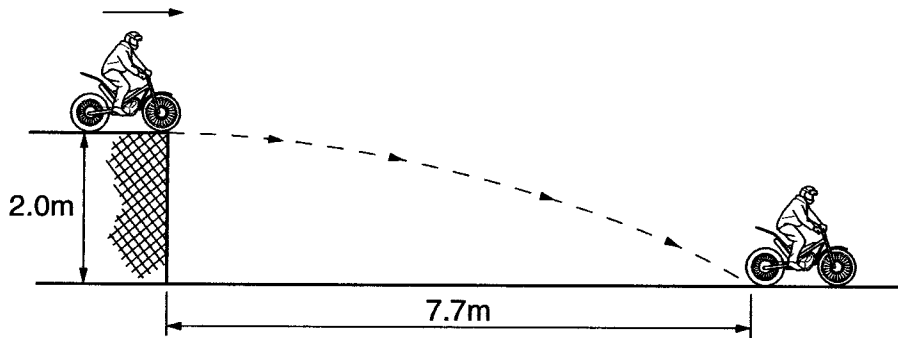

Fig. 6.1

He lands on the ground 7.7 m away as shown.

- (a) By considering his vertical motion only, show that the time taken to reach the ground after he has taken off is about 0.6 s. Neglect the effects of any resistive forces.

acceleration due to gravity = 9.8 m s^{-2}

[2]

- (b) Calculate the horizontal velocity at which he leaves the launching point.

velocity = m s^{-1} [2]

[Section A Total: 20]

[Turn over



Section B

7 This question is about superposition of radio waves.

(a) A transmitting aerial emits radio waves of frequency 1.0 GHz.

Show that the wavelength of the radio waves is 30 cm.

speed of electromagnetic waves in vacuum = $3.0 \times 10^8 \text{ ms}^{-1}$

[2]

(b) In the experimental arrangement shown in Fig. 7.1, waves emitted from the transmitting aerial are detected at the receiving aerial.

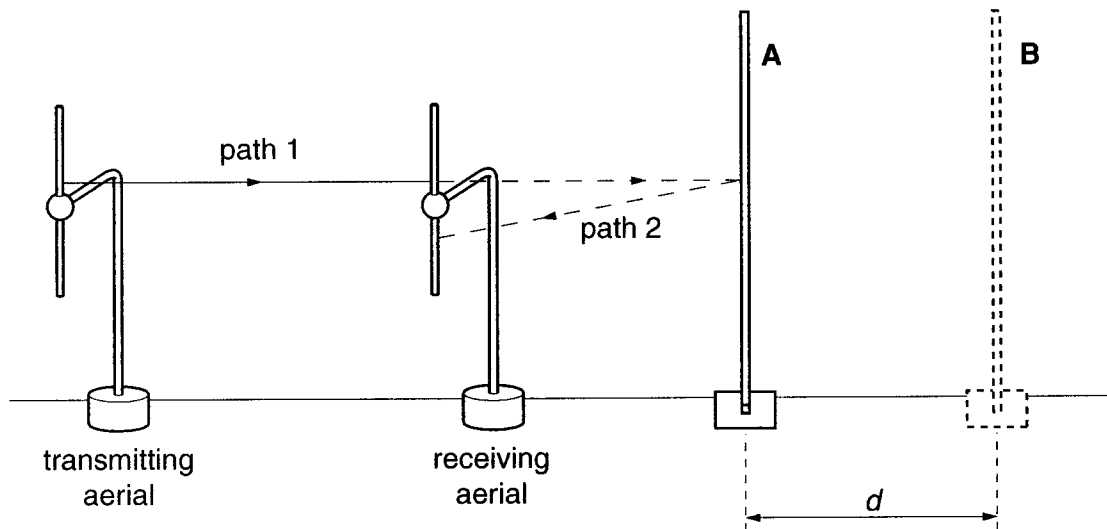

Fig. 7.1

Waves travel to the receiver along two paths: directly from the transmitter (path 1) and by reflection from the metal sheet (path 2). The waves arriving at the receiver are combined to give a resultant signal. As the metal plate is moved away from the receiver, the resultant signal rises and falls.

(i) With the metal plate in position **A**, the output signal from the receiver is a **maximum**.

Explain in terms of superposition of waves how a maximum signal can occur at the receiver.

[2]



- (ii) The metal plate is moved away from the receiver to position **B**, causing the output signal to decrease to a **minimum**.

Use the idea of superposition of waves to explain why the signal has decreased to a minimum.

[2]

- (iii) Explain why the minimum signal is not necessarily zero.

[2]

- (iv) Calculate the distance d between the positions **A** and **B** of the metal plate shown in Fig. 7.1 for radio waves of wavelength 30 cm. Make your reasoning clear.

Express your answer in cm.

$d = \dots\dots\dots$ cm [2]

[Total: 10]

[Turn over



- 8 A rocket propelled model car accelerates from rest along a horizontal track as shown in Fig. 8.1.



Fig. 8.1

- (a) The mass of the car is 0.80 kg and the forward thrust provided by the rocket is 3.0 N.

Calculate the initial acceleration of the car.

acceleration = ms^{-2} [2]

- (b) The speed of the car increases at a decreasing rate to a maximum speed. The car then continues along the track at this constant speed. Throughout the motion the forward thrust on the car remains constant at 3.0 N.

Explain, in terms of the forces acting on the car, why

- (i) the **acceleration** of the car decreases as the speed increases

[2]

- (ii) the car reaches a constant speed.

[2]



- (c) When the car has travelled further down the track, a parachute, attached to the rear of the car, is opened. The forward thrust remains unchanged at 3.0N.

Fig. 8.2 is a sketch graph showing how the velocity of the car changes from the moment the parachute opens at time $t=0$.

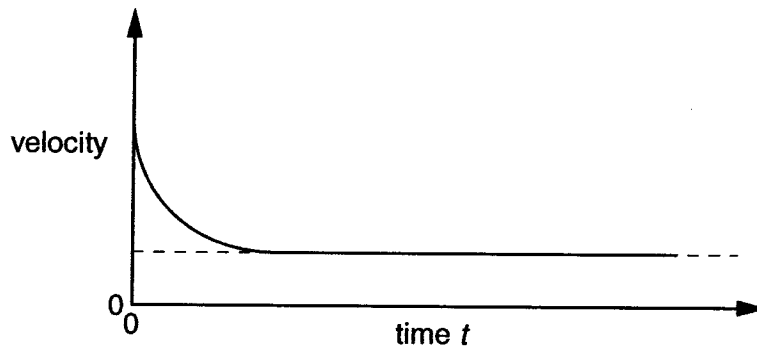

Fig. 8.2

- (i) Use the graph to describe how the motion of the car changes from the instant the parachute is opened.

[2]

- (ii) Explain why the motion of the car changes in the way you have described.

[2]

[Total: 10]
[Turn over



9 This question is about standing waves.

Fig. 9.1 shows a standing wave on a steel guitar string stretched between two supports.

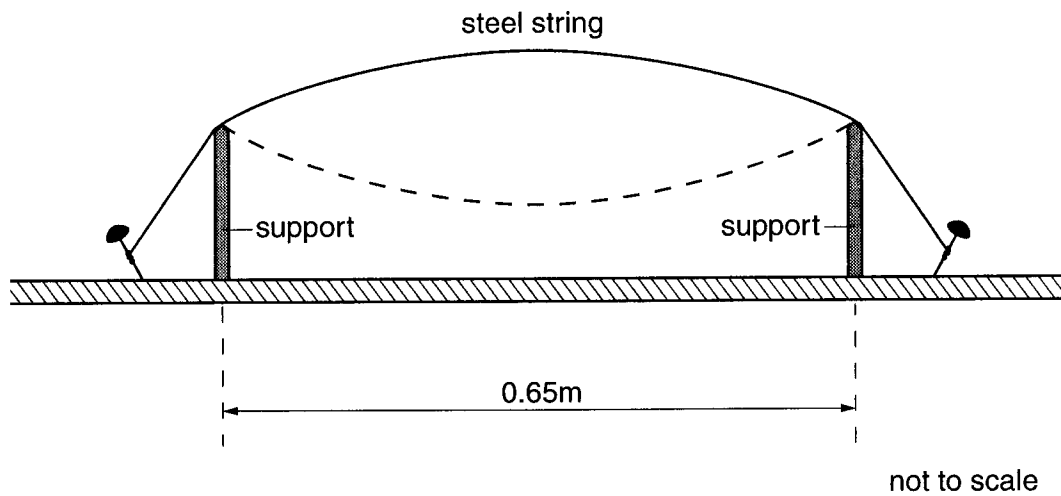

Fig. 9.1

(a) (i) The length of the string between the supports is 0.65m.

State the wavelength of the standing wave.

wavelength = m [1]

(ii) The fundamental standing wave shown produces a note of frequency 280 Hz.

Calculate the speed of the waves along the string.

speed = ms^{-1} [2]



- (b) The fundamental frequency f of a standing wave on a stretched string is given by

$$f = \frac{1}{2L} \sqrt{\frac{T}{\mu}}$$

where L is length of the string between the supports, T is the tension and μ is the mass per unit length of the string.

- (i) The tension in the guitar string shown in Fig. 9.1 is doubled.

Calculate the frequency of the new fundamental note. Assume that μ remains constant.

frequency = Hz [2]

- (ii) In practice, the mass per unit length μ changes because the string gets thinner when the tension is increased.

State and explain the effect this would have on the frequency.

[2]

- (c) By placing a finger lightly at certain places along the string, it is possible to produce standing wave patterns of different frequencies.

- (i) Sketch on Fig. 9.1 one of these standing wave patterns. [1]

- (ii) Calculate the frequency of the note produced by the standing wave you have sketched. Assume that the frequency of the fundamental is still 280 Hz.

frequency = Hz [2]

[Total: 10]

[Turn over



10 This question is about relative velocity.

Fig. 10.1 shows two aircraft K and L, in level flight at the same altitude, approaching a radar beacon at M.

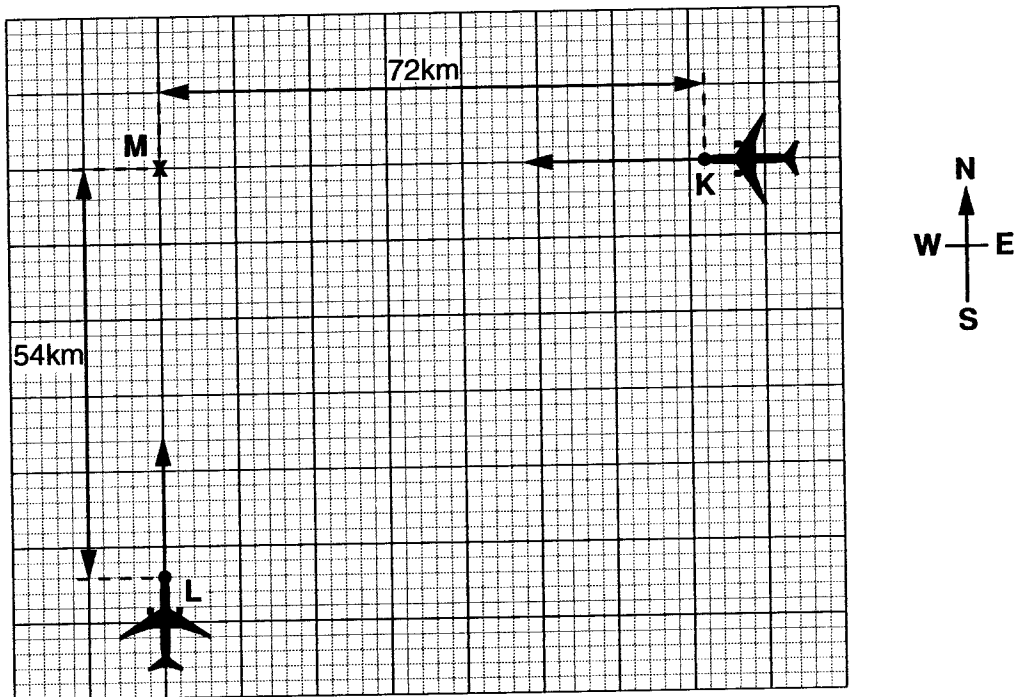

Fig. 10.1

- (a) Use the information on the diagram to show that the **displacement** of aircraft K from aircraft L is 90 km, 53° East of North, when the aircraft are in the positions shown. You may find it helpful to draw a diagram in the space below.

[2]



(b) Aircraft L is flying due North at 900 km h^{-1} and aircraft K is flying due West at 1200 km h^{-1} . The magnitudes and directions of the velocity vectors are drawn to scale on Fig. 10.1. Scale: 1 cm represents 500 km h^{-1} .

(i) At the instant shown, the magnitude of the relative velocity of approach of aircraft L to aircraft K is 1500 km h^{-1} in a direction directly towards aircraft K.

Confirm this either by scale drawing on Fig. 10.1, or by some other method of your choosing.

[4]

(ii) Describe the position of aircraft L when aircraft K passes over point M, if the aircraft go on flying at their present velocities.

[1]

(c) Air traffic control rules do not permit aircraft to fly on paths like those shown in Fig. 10.1 at distances closer than 60 km.

Calculate the time taken for the aircraft to reach a position 60 km apart, from the instant shown in Fig. 10.1. Express your answer in seconds.

time = s [3]

[Total: 10]

[Section B Total: 40]

[Turn over



Section C

In this section of the paper, you will choose the context in which you give your answers.

Use diagrams to help your explanations and take particular care with your written English. In this section, four marks are available for the quality of written communication.

11 In this question, you are to choose and write about a phenomenon that can be explained in terms of quantum behaviour.

(a) State the phenomenon you have chosen.

[1]

(b) Draw a labelled diagram to show how the phenomenon can be observed.

[4]



(c) Describe what could be observed with this apparatus.

[4]

(d) Explain the observations you have described in (c), in terms of quantum behaviour. Give any relevant equations as part of your explanation.

[4]

[Total: 13]

[Turn over



- 12 In this question, you are to choose how to measure the acceleration of a trolley moving down an inclined runway.

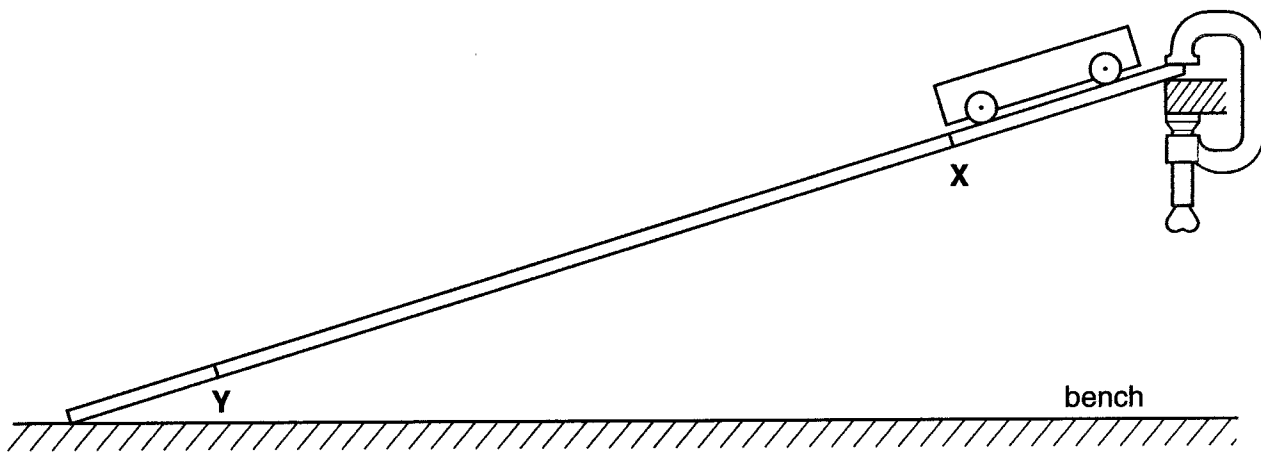

Fig. 12.1

An inclined runway is set up on a bench. One end of the runway is firmly supported above the bench in the position shown in Fig. 12.1.

The trolley is released from point **X** and accelerates uniformly down the runway to point **Y**.

- (a) State the quantities that would need to be measured to find the acceleration of the trolley.

[2]

- (b) (i) Describe and explain how you would make the measurements. You may add to Fig. 12.1 if you wish.

[4]



(ii) Show how the quantities would be used to find a value for the acceleration.

[3]

(c) (i) Suggest **two** different factors that might limit the accuracy of the measurement of the acceleration.

1.

2.

[2]

(ii) Suggest and explain **one** way the accuracy might be improved.

[2]

[Total: 13]

[Quality of Written Communication: 4]

[Section C Total: 30]

END OF QUESTION PAPER

